

F Series

	MC-36-F	MC-45-F	MC-54-F
Cutting width (mm)	920/36"	1,150/45"	1,370/54"
Max. Cutting Height (mm)	130/5.1"	165/6.5"	165/6.5"
Max. Cutting Length (mm)	920/36"	1,150/45"	1,450/57"
Max. Cuts per Minute	48	48	48
Max. Speed of Backgauge (m/min)	13.5	18	18
Table Height	35.5"	35.5"	35.5"
Net. Weight (lbs)	4,620	7,700	8,360
Length of Front table (mm)	749/29.5"	715/28.1"	730/28.7"
Length of Table (mm)	2,180/85.8"	2,490/98"	2,770/109.1"
Max. Clamp Pressure (kgs/lbs)	3,500/7,700	4,500/9,900	5,600/12,320
Power/3Phase 220V	3KW/25A	4KW/30A	4KW/30A

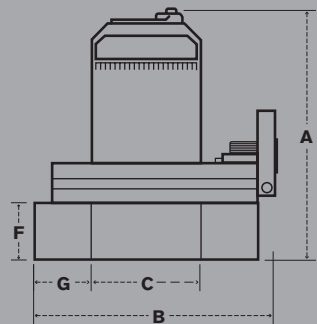

Model	A	B	C	D	E	F	G
30"	(in) 82.00 (cm) 208.00	78.50 200.00	30.70 78.00	35.50 90.00	60.00 152.00	19.00 48.00	23.50 60.00
36"	(in) 84.00 (cm) 214.00	86.50 220.00	36.25 92.00	35.50 90.00	60.00 152.00	16.75 42.50	23.50 60.00
45"	(in) 111.75 (cm) 284.00	123.75 315.00	45.25 115.00	35.50 90.00	66.00 167.60	29.50 75.00	39.25 100.00
54"	(in) 121.50 (cm) 309.00	132.50 336.00	54.00 137.00	35.50 90.00	66.00 167.60	29.50 75.00	39.25 100.00
61"	(in) 127.25 (cm) 324.00	147.00 375.00	61.00 155.00	35.50 90.00	69.50 176.50	29.50 75.00	39.25 100.00

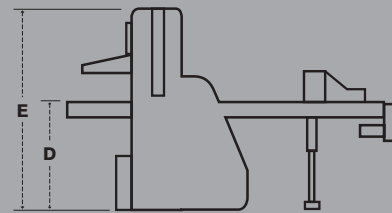

S Series

	MC-30-S	MC-36-S	MC-45-S	MC-54-S	MC-61-S	MC-65-S	MC-73-S	MC-86-S
Cutting Width (mm)	780/30.7"	920/36"	1,150/45"	1,370/54"	1,550/61"	1,660/65"	1,860/73"	2,200/86."
Max. Cutting Height (mm)	120/4.7"	130/5.1"	165/6.5"	165/6.5"	165/6.5"	165/6.5"	165/6.5"	165/6.5"
Max. Cutting Length (mm)	780/30.7"	920/36"	1,150/45"	1,450/57"	1,550/61"	1,700/67"	1,950/77"	2,200/86.6"
Max. Cuts per Minute	45	45	42	42	36	28	40	30
Max. Speed of Backgauge (m/min)	10	10	12	12	12	12	12	12
Table Height	35.5"	35.5"	35.5"	35.5"	35.5"	35.5"	35.5"	35.5"
Net. Weight (lbs)	3,960	4,620	7,700	8,360	13,090	15,400	22,000	24,200
Length of Front Table (mm)	670/26.4"	749/29.5"	715/28.1"	730/28.7"	750/29.5"	750/29.5"	750/29.5"	750/29.5"
Length of Table (mm)	1950/76.8"	2180/85.8"	2490/98"	2770/109.1"	2890/113.8"	3237/127.4"	3410/134.3"	3750/147.6"
Max. Clamp pressure (lbs)	6,600	7,700	9,900	12,320	13,420	13,420	15,730	15,730
Max. Clamp pressure (kgs)	3,000	3,500	4,500	5,600	6,100	6,100	7,150	7,150
Power/3 Phase 220V	3KW/25A	3KW/25A	4KW/30A	4KW/30A	5.5KW/40A	5.5KW/40A	7.5KW	11KW

F Series

S Series

Precision, Performance, Affordability



MICRON™ CUTTERS



Micron paper cutters are manufactured by S.W.D. Ltd., the second largest producer of paper cutters in the world today. With over 900 units installed in the U.S., and more than 2,000 units shipped each year, their reputation speaks for itself. Micron paper cutters are built using modern manufacturing techniques in a facility incorporating state of the art CNC machine tools. With more than 45 years of experience in manufacturing paper cutters, S.W.D. Ltd. has a proven track record of producing heavy duty paper cutters of the highest quality. S.W.D. Ltd. has received ISO 9001 certification (Reg. No. SC0197A145). These paper cutters are designed for many years of trouble-free operation at a very competitive price.



Micron Paper Cutter Features

- Chrome Table surface (main & side tables)
- CE Labeled Infra-Red Beams (German made)
- CE Electrical Components
- Cutting process monitors
- Emergency stop switch
- Air table with blower
- Self-locking worm gear, wear resistant
- Ball screw and liner guide for backgauge moving
- Built-in Gravity safety latch
- Table slot-closing device
- Side gauges fixed, right/left
- Reliable CE Labeled Hydraulic System (German made)
- Machine Overload Protection Mechanical System with Electrical Monitoring
- Two-hand cut release, with time limitation and non-repeat device
- Adjustable clamp pressure by hand switch at operation panel
- Removable False clamp (to be fixed from the front side)
- Covers for moving parts and hazardous areas
- Two (2) High Speed Steel Knives
- Knife lifting device for quick knife change
- Six plastic cutting sticks
- Toolbox with complete set of tools, operation manual
- One (1) Paper Jogging Block

Built with the Latest Technology, Quality Components, and a Proven Design



S Series

The Micron S Series is a well-made durable and reliable line of work horse paper cutters offered in a full range of sizes from 30" to 86". All of our Micron paper cutters are built to last!



We also offer a full complement of cutting line equipment for increased speed and efficiency

F Series

The Micron F Series offers the same dependable performance as the S Series, with improved styling and performance. Improved cutting speed results from the backgauge being able to move before the clamp is back in the top position, as well as the high-speed ball screw which moves the backgauge at a faster rate (18m/minute vs. 12m/minute). This translates to a 14% faster cutting cycle and higher productivity for busy shops. 10" TFT color touch screen-computerized back gauge control/USB interface for memory storage/Network & full CIP3/4 compatible.

Built-in Gravity Safety Latch



False Clamp

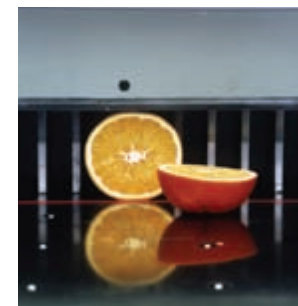

German Hydraulic System



Ball Screw with Liner Guide



Microcut® Computer Control System

